

Multi-fixations



Bride

2,7 Tonnes
27000 Newton



Bride Multi-fixation

Excent.	A	B	C	D	E	F	G	H	I	J	K	Puissance Fixation	Réf.
M 10	19	1.56	7	19	6.4	11.7	63.5	7.9	21	21.2	15.7	3400 N.	M 8 MB-510
M 12	28.4	2.03	8	25.4	9.5	12.2	95.2	9.4	42.5	30.6	15.7	18000 N.	M 12 MB-520
M 16	38.1	2.54	12	38.1	12.7	35	107	9.4	46.2	51.4	41.1	27000 N.	M 16 MB-530

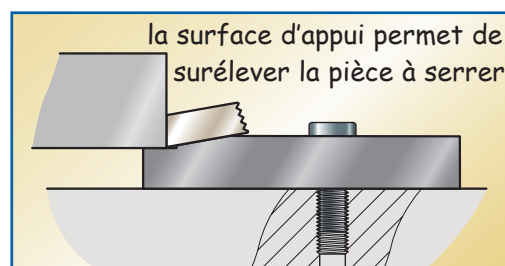
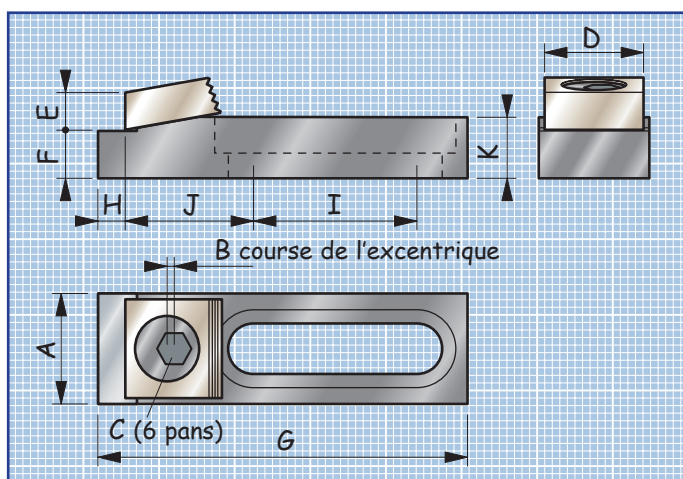

pour Modulaire et Rainures en Té

Butées d'appui

A	B	C	D	E	F	G	pour bride	Fixation	Réf.
19	11.7	63.5	7.9	21	21.1	15.7	3400 N.	M 8	MB-511
28.4	12.2	95.2	9.4	42.5	30.6	15.7	18000 N.	M 12	MB-521
38.1	35	107	9.4	46.2	51.4	41.1	27000 N.	M 16	MB-531



Butée

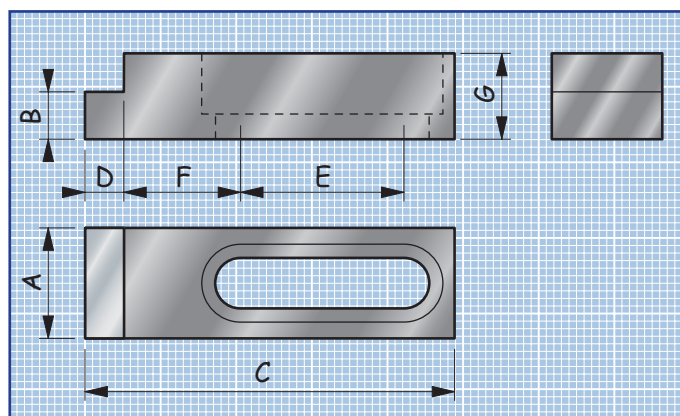

BRIDAGE HORIZONTAL 3

Kit de bridage

comprenant 4 Brides surélevées,
1 Rail de positionnement
1 butée latérale

Fixation	Rainure	Puissance	Réf.
M 8	10	360 kg	MB-628
M 10	12	1800 kg	MB-620
M 12	14	1800 kg	MB-622
M 12	16	1800 kg	MB-624
M 12	18	1800 kg	MB-626



1,8 Tonne
18000 Newton

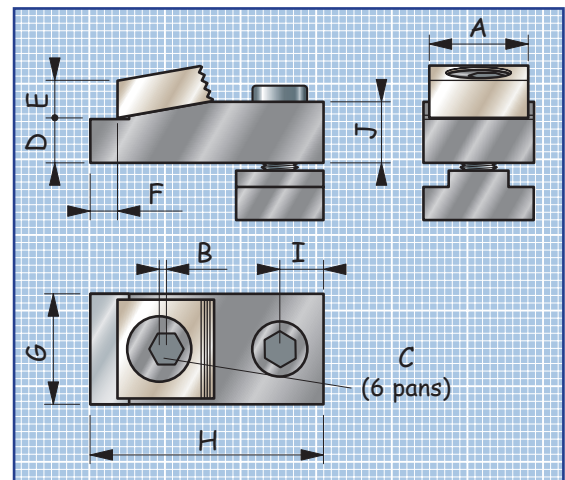

Brides surélevées (jeu de 4 brides et 2 clés de serrage)

Fixation	Rainure	A	B	C	D	E	F	G	H	I	J	Puissance	Réf.
M 8	10	19	1.5	7	11.7	6.35	7.9	19.1	63.5	21	15.8	3600 N.	MB-628*
M 10	12												MB-610
M 12	14												MB-612
M 12	16	25.4	2	8	12.2	9.5	6.35	28.45	63.5	20	15.8	18000 N.	MB-614
M 12	18												MB-616

*Réf. vendue uniquement en Kit Complet

Rail de positionnement avec butée latérale

Fixation	Rainure	A	B	C	D	E	F	G
M 8	10	127	11.7	18.8	18.3	31.5	24.9 à 50.3	63.5
M 10 et M 12	12 à 18	198.1	12.2	21.9	31.2	43.9	49.8 à 80.25	99.05

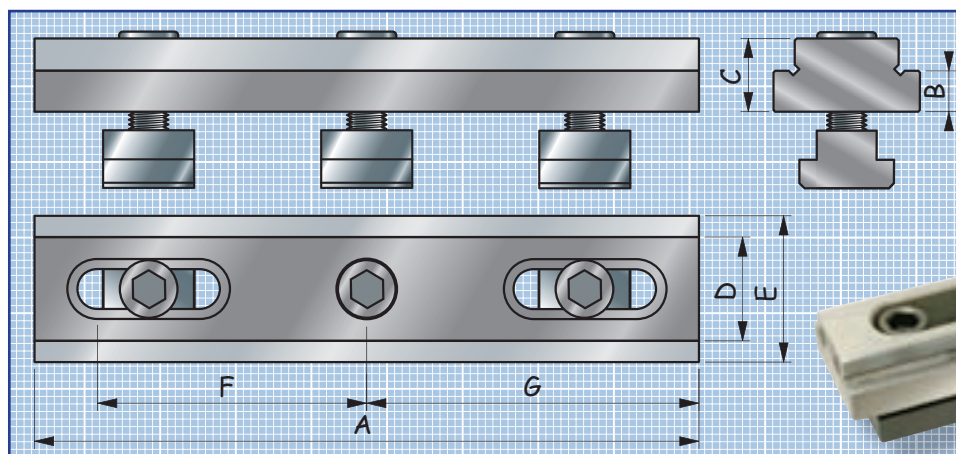

Le rail et sa butée
sont vendus avec les
kits complets

